

TP-CA230

40 PIES

KIT REFORMA DOBLE MANDO CARDANICO

APLICABLE A DRAPERS:

-CASE® 3162 TERRA FLEX 40 PIES.

-NEW HOLLAND® 840CD 40 PIES.

Este sistema es reemplazado por 2 cajas de cuchilla TP-CA2012-4

COMPONENTES













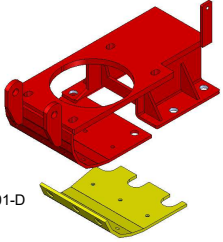
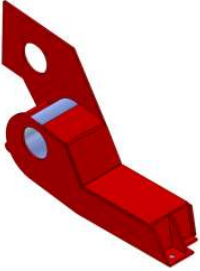
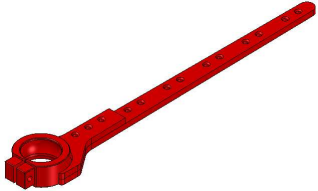

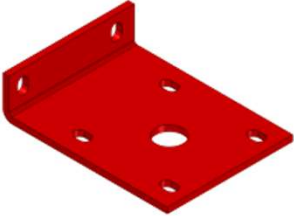
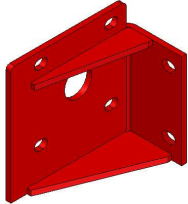

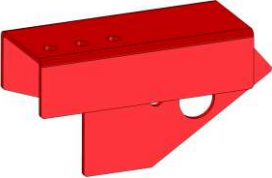
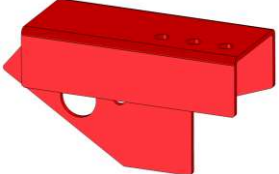
TECNOLOGIA PEREZ

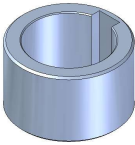





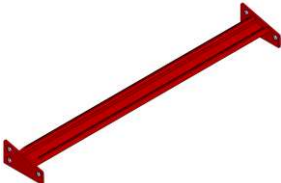



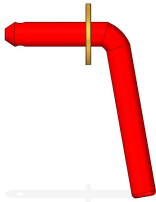
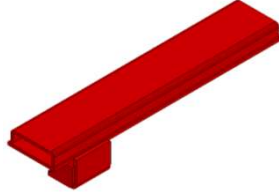
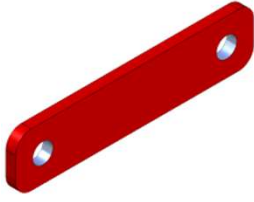

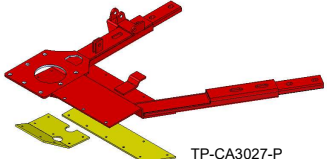

TEL: 02273 442214

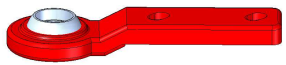













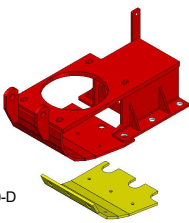

contacto@tecperez.com.ar

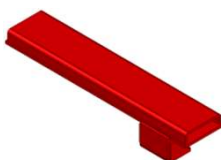
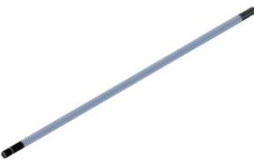

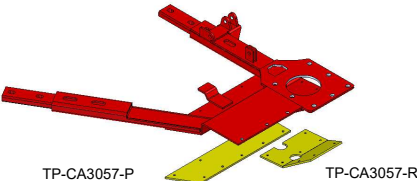







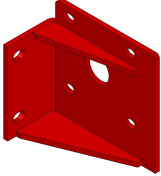

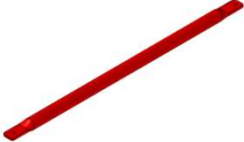

www.tecnologiaperez.com.ar

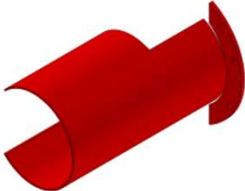



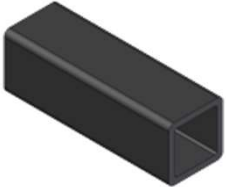
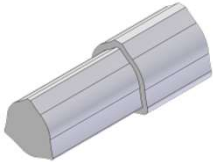



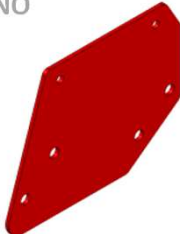

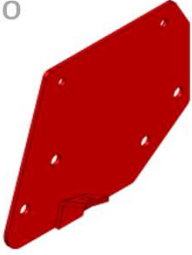
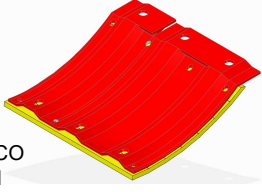
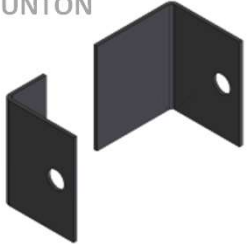



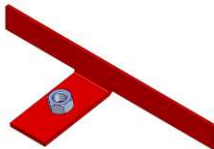

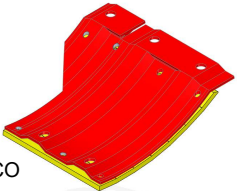
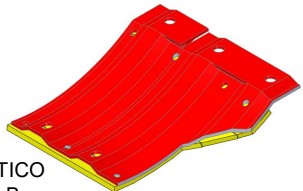





| | | |
|---|--|---|
| <p>TP-CA3001 BASE DERECHA CANT. 1</p>  <p>TP-CA3001-D</p> | <p>TP-CA3002 CAJON CANT. 1</p>  | <p>TP-CA3004 CABEZA DE CUCHILLA DER CANT. 1</p>  |
| <p>TP-CA3005 PROLONGACION LAT IZQ/DER CANT. 2</p>  | <p>TP-CA3006 FIJADOR MOTOR DER CANT. 2</p>  | <p>TP-CA3008 ESCUADRA INFERIOR CANT. 1</p>  |
| <p>TP-CA3009 COBERTOR DRAPER CENTRAL CANT. 1</p>  | <p>TP-CA3010 SOP. TENSOR RESORTE DER. CANT. 1</p>  | <p>TP-CA3011 SOP. TENSOR RESORTE IZQ. CANT. 1</p>  |
| <p>TP-CA3012 CAJA SOP. COBERTOR PLASTICO CANT. 6</p>  | <p>TP-CA3013 BUJE CORTO CANT. 2</p>  | <p>TP-CA3014 BUJE CANT. 2</p>  |
| <p>TP-CA3015 EJE SALIDA MULTIPLICADOR CANT. 1</p>  | <p>TP-CA3016 EJE DE MANDO DERECHO (L 2900) CANT. 1</p>  | <p>TP-CA3018 BRAZO REG. PUNTON IZQ. CANT. 1</p>  |
| <p>TP-CA3019 BRAZO REG. PUNTON DER. CANT. 1</p>  | <p>TP-CA3020 ESTABILIZADOR CENTRAL DRAPER CANT. 1</p>  | <p>TP-CA3021 - CANT. 4</p>  |

| | | |
|--|---|---|
| <p>TP-CA3022 TRABA BALANCIN TRIGO/SOJA CANT. 2</p>  | <p>TP-CA3023 SOPORTE INFERIOR ROTULA BALANCIN CANT. 1</p>  | <p>TP-CA3024 SOPORTE SENSOR CANT. 2</p>  |
| <p>TP-CA3025 ESCUADRA INF. SOP. BRAZO BALANCIN CANT. 2</p>  | <p>TP-CA3026 SOPORTE DERECHO CANT. 1</p>  | <p>TP-CA3027 BALANCIN DERECHO CANT. 1</p>  <p>TP-CA3027-R TP-CA3027-P</p> |
| <p>TP-CA3028 BANCADA 1 LADO DER. (LADO CAJA) CANT. 1</p>  | <p>TP-CA3029 BANCADA 2 LADO DER. (CENTRAL) CANT. 1</p>  | <p>TP-CA3030 BANCADA 3 LADO DER. (LADO MANDO) CANT. 1</p>  |
| <p>TP-CA3031 ROTULA INFERIOR AJUSTE BALANCIN CANT. 4</p>  | <p>TP-CA3032 SOPORTE BALANCIN CANT. 2</p>  | <p>TP-CA3033 ALARGUE CHASIS DER. CANT. 1</p>  |
| <p>TP-CA3035 SOPORTE CAPOT LADO DERECHO CANT. 1</p>  | <p>TP-CA3036 CAJA SALIDA MULTIPLICADOR CANT. 1</p>  | <p>TP-CA3037 TUERCA FIJA INTERNA CAJA MULTIPLICADORA CANT. 1</p>  |
| <p>TP-CA3038 COBERTOR CRUCETAS SALIDA CAJA ESCUADRA CANT. 2</p>  | <p>TP-CA3039 REFUERZO PARA TP-CA 3028 CANT. 1</p>  | <p>TP-CA3040 REFUERZO PARA TP-CA 3029 CANT. 1</p>  |

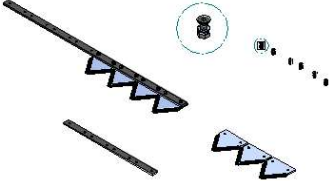
| | | |
|---|---|--|
| <p>TP-CA3041 REFUERZO PARA TP-CA 3030 CANT. 1</p>  | <p>TP-CA3043 BARRA DE MANDO HEMBRA CANT. 1</p>  | <p>TP-CA3044 BARRA DE MANDO MACHO CANT. 1</p>  |
| <p>TP-CA3046 BARRA DE MANDO HEMBRA LATERAL CANT. 2</p>  | <p>TP-CA3047 BARRA DE MANDO MACHO LATERAL CANT. 2</p>  | <p>TP-CA3048 CONJUNTO PUNTONES CENTRALES CANT. 1</p>  |
| <p>TP-CA3050 BASE IZQUIERDA CANT. 1</p>  <p>TP-CA3050-D</p> | <p>TP-CA3051 CAJON IZQUIERDO CANT. 1</p>  | <p>TP-CA3052 TALON IZQUIERDO CANT. 1</p>  |
| <p>TP-CA3054 SOPORTE INF. ROTULA BALANCIN CANT. 1</p>  | <p>TP-CA3055 EJE CORTO LADO IZQUIERDO (L 1720) CANT. 1</p>  | <p>TP-CA3056 SOPORTE CANT. 1</p>  |
| <p>TP-CA3057 BALANCIN IZQUIERDO CANT. 1</p>  <p>TP-CA3057-P TP-CA3057-R</p> | <p>TP-CA3058 ALARGUE CHASIS IZQUIERDO CANT. 1</p>  | <p>TP-CA3060 SOPORTE CAPOT LADO IZQUIERDO CANT. 1</p>  |
| <p>TP-CA3061 BARRA DE MANDO HEMBRA LADO IZQUIERDO CANT. 1</p>  | <p>TP-CA3062 BARRA DE MANDO MACHO LADO IZQUIERDO CANT. 1</p>  | <p>TP-CA3063 PATIN CUBRE ROTULA CANT. 1</p> <p>OPCIONAL</p>  |

| | | |
|--|---|---|
| <p>TP-CA3065 ESCUADRA INFERIOR IZQUIERDA CANT. 1</p>  | <p>TP-CA3066 SEPARADOR CANT. 2</p>  | <p>TP-CA3067 VARILLA CANT. 1</p>  |
| <p>TP-CA3068 CAÑO ESTABILIZADOR CANT. 1</p>  | <p>TP-CA3069 APOYO TIRETA CANT. 1</p>  | <p>TP-CA3070 BANCADA 1 LADO IZQUIERDO (LADO CAJA) CANT. 1</p>  |
| <p>TP-CA3071 BANCADA LADO IZQ. LADO MANDO CANT. 1</p>  | <p>TP-CA3072 CUBRE CRUCETAS CANT. 1</p>  | <p>TP-CA3073 EJE UNION DE PARALELAS C/CAJON CANT. 2</p>  |
| <p>TP-CA3074 COBERTOR EJE DE MANDO LADO IZQUIERDO CANT. 1</p>  | <p>TP-CA3075 COBERTOR EJE DE MANDO LADO DERECHO (LADO CENTRAL) CANT. 1</p>  | <p>TP-CA3076 COBERTOR EJE DE MANDO LADO DERECHO (LADO LATERAL) CANT. 1</p>  |
| <p>TP-CA3078 REFUERZO PARALELAS CANT. 2</p>  | <p>TP-CA3079 ESPIGA UNION TRILOBULAR CANT. 2</p>  | <p>TP-CA3080 PUNTON TRIPLE P/LATERAL IZQ. DRAPER CANT. 1</p>  |
| <p>TP-CA3081 PUNTON TRIPLE P/LATERAL DER. DRAPER CANT. 1</p>  | <p>TP-CA3082 DISCO SEPARADOR CAJA ESCUADRA CANT. 2</p>  | <p>TP-CA3083 LATERAL INTERNO CANT. 1</p>  |

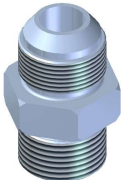
| | | |
|--|---|--|
| <p>TP-CA3084 LATERAL EXTERNO CANT. 1</p>  | <p>TP-CA3086 PATIN CENTRAL CANT. 1</p>  <p>PAT. PLASTICO TP-377581 A1</p> | <p>TP-CA3087 REFORMA PUNTON CANT. 2</p>  |
| <p>TP-CA3088 ENGANCHE BARRA DE MANDO IZQUIERDO CANT. 1</p>  | <p>TP-CA3089 ENGANCHE BARRA DE MANDO DERECHO CANT. 1</p>  | <p>TP-CA3090 SOPORTE IZQ. TIRETA BALANCIN CANT. 1</p>  |
| <p>TP-CA3091 SOPORTE DER. TIRETA BALANCIN CANT. 1</p>  | <p>TP-CA3092 SOPORTE IZQ. COBERTOR CRUZETAS CANT. 1</p>  | <p>TP-CA3093 SOPORTE DER. COBERTOR CRUZETAS CANT. 1</p>  |
| <p>TP-CA3094 PATIN IZQUIERDO CANT. 1</p>  <p>PAT. PLASTICO TP-CA3094-B</p> | <p>TP-CA3095 PATIN DERECHO CANT. 1</p>  <p>PAT. PLASTICO TP-CA3095-B</p> | <p>TP-CA3096 MANGUERA DE COMANDO A "T" DE BOMBA CANT. 1</p>  |
| <p>TP-CA3097 MANGUERA CENTRALINA CANT. 1</p>  | <p>TP-CA3098 UNION CARDANICA CANT. 2</p>  | <p>TP-CA3099 BRIDA AJUSTE SUPERIOR CANT. 1</p>  <p>OPCIONAL</p> |
| <p>666-204 CONJUNTO CUCHILLAS DER/IZQ PARA 35/40 PIES CANT. 1</p> | <p>666-333 BARRA PUNTONERA CANT. 2</p> | <p>6022 COBERTOR CANT. 2</p>  |

| | | |
|--|---|---|
| <p>TP-CA2012-4 CAJA DE CUCHICHA CANT. 2</p>  | <p>TP-CE100 CAJA ESCUADRA CANT. 2</p>  | <p>TP-47845725REF EMBRAGUE TOMA DE FUERZA DRAPER CANT. 2</p>  |
| <p>TP-CA2506 CONJUNTO CUCHILLAS CANT. 1</p>  | <p>1313103 C1TP RESORTE ARMADO CANT. 2</p>  <p>TP-124366 A1 TP-1313103 C1 TP-1313104 C1</p> | <p>TP-124365 A1 TORNILLO ESPECIAL CANT. 2</p>  |
| <p>47-01854 ROTULA CANT. 2</p>  | <p>PH-48 NIPLA 1-1/16 JIC A M27 CANT. 2</p>  | <p>555100101 FUELLE CANT. 2</p>  |
| | | |
| | | |
| | | |

BULONERIA TP-CA230:

| CANT. | DESCRIPCION | MEDIDA | CON | UBICACIÓN |
|-------|-------------------|----------|------------------------------------|---------------------------------------|
| 2 | TORNILLOS | 16 x 140 | TUERCAS FLANGE | MULTIPLICADOR |
| 2 | TORNILLOS | 16 x 130 | TUERCA AUTOFRENANTE | PUNTON ORIGINAL |
| 8 | TORNILLOS | 16 x 60 | TUERCAS FLANGE | BRAZO A ROTULAS |
| 4 | TORNILLOS | 16 x 60 | TUERCAS FLANGE | ROTULA |
| 10 | TORNILLOS | 16 x 40 | TUERCAS FLANGE | BASE A BALANCIN |
| 4 | TORNILLOS | 16 x 35 | TUERCAS COMUNES | BASE CAJA A BALANCIN |
| 3 | TORNILLOS | 16 x 30 | TUERCAS Y GROWER | PARALELAS ALARGUE MULTIPLICADOR |
| 1 | TORNILLO | 16 x 22 | TUERCA FLANGE (SE CORTA UNO DE 30) | PARALELAS ALARGUE MULTIPLICADOR |
| 2 | TORNILLOS | 12 x 140 | TUERCAS FLANGE | PARALELAS ALARGUE MULTIPLICADOR |
| 22 | TORNILLOS | 12 x 70 | TUERCAS AUTOFRENANTES | CRUZETAS |
| 2 | TORNILLOS | 12 x 60 | TUERCAS AUTOFRENANTES | RESORTE ESTABILIZADOR |
| 8 | TORNILLOS | 12 x 50 | TUERCAS AUTOFRENANTES Y PLANAS | CAJAS CUCHILLAS |
| 16 | TORNILLOS | 12 x 40 | | AJUSTE FALSO CHASIS LAT. A PLATAFORMA |
| 2 | TORNILLOS | 12 x 35 | AUTOFRENANTES | AGUJA M DE ALTURA |
| 4 | TORNILLOS | 12 x 35 | 8 TUERCAS FLANGE | TAPA LATERAL CUCHILLA |
| 2 | TOR CAB RED FRENT | 12 x 40 | AUTOFRENANTES | TIRETA FIN DE CARRERA |
| 16 | TORNILLOS | 12 x 30 | ARANDELAS PLANAS Y GROWER | CHASIS INFERIOR |
| 2 | TORNILLOS | 12 x 30 | PLANAS | MULTIPLICADOR PARTE SUPERIOR |
| 2 | TORNILLOS | 12 x 30 | TUERCAS FLANGE | 2 BARRA MULTIPLICADOR |
| 2 | TORNILLOS | 12 x 30 | TUERCAS FLANGE | SOPORTE BARRA MANDO DERECHA |
| 2 | TORNILLOS | 12 x 30 | TUERCAS FLANGE | SOPORTE BARRA MANDO IZQUIERDA |
| 6 | TORNILLOS | 12 x 30 | TUERCAS FLANGE | BARRA CENTRAL ESTABILIZADORA |
| 2 | TORNILLOS | 12 x 25 | TUERCAS FLANGE | TIRETA A CHASIS |
| 2 | TORNILLOS | 12 x 25 | TUERCAS FLANGE | SOPORTE BARRA CARDANICA IZQUIERDA |

BULONERIA TP-CA230:

| CANT. | DESCRIPCION | MEDIDA | CON | UBICACIÓN |
|-------|---------------------|---------|------------------------------------|---------------------------------|
| 8 | TORNILLOS | 10 x 55 | ARANDELAS BICELADAS | CAJA ESCUADRA |
| 2 | C/RC | 10 x 50 | TUERCAS FLANGE | PUNTON CENTRAL |
| 8 | TORNILLOS | 10 x 40 | PLANAS | EJE SALIDA CAJA A BOLANTE |
| 8 | TORNILLOS | 10 x 35 | TUERCAS FLANGE Y ARANDELA BICELADA | SOP. CAJA ESCUADRA |
| 6 | TORNILLOS C/CUADR | 10 x 35 | TUERCAS FLANGE | PUNTONES TRIPLES LATERALES |
| 4 | TOR CAB RED C/CUA | 10 x 30 | TUERCAS FLANGE | SENSORES |
| 2 | TORNILLO | 10 x 25 | TUERCA FLANGE | SOPORTE BARRA |
| 20 | TORNILLOS | 10 x 25 | ARANDELAS GROWER | AJUSTE BARRA PUNTONERA |
| 6 | TORNILLOS | 10 x 25 | TUERCAS FLANGE | BALANCIN A BARRA PUNTONERA |
| 4 | TORNILLOS C/CUADR | 10 x 25 | TUERCAS FLANGE | AJUSTE TIRETA PUNTON |
| 8 | TORNILLOS | 10 x 20 | ARANDELAS BICELADAS | CAJA ESCUADRA A ESCUADRA |
| 8 | TORNILLOS | 10 x 20 | ARANDELAS PLANAS DE 3/8 | ESCUADRA INFERIOR CAJA |
| 4 | TORNILLOS | 10 x 20 | ARANDELAS PLANAS Y GROWER | ESCUADRA INFERIOR |
| 4 | TORNILLOS C/R | 10 x 20 | TUERCAS FLANGE | SENSOR |
| 2 | TORNILLOS | 8 x 50 | TUERCAS AUTOFRENANTES | CABEZA CUCHILLA |
| 2 | TORNILLOS | 8 x 30 | TUERCAS FLANGE | CAPOT SOPORTE INFERIOR |
| 3 | TORNILLOS | 8 x 30 | | COBERTOR MULTIPLICADOR |
| 5 | TORNILLOS | 8 x 25 | GROWER | CAJA ARO MULTIPLICADOR |
| 4 | TOR CAB RED C/CUA | 8 x 25 | TUERCAS FLANGE | |
| 6 | TORNILLOS | 8 x 20 | FLANGE | AJUSTE CAPOT LATERAL |
| 4 | TOR ALL CAB BOTON | 8 x 20 | | PATIN BALANCÍN ROTULA |
| 8 | TORNILLOS | 8 x 15 | TUERCAS FLANGE | ALARGUE LATERAL CAPOT PARTE SUP |
| 36 | TORNILLOS (665-013) | 6 | TUERCAS | TALON DE CUCHILLAS |
| 12 | TORNILLOS | 6 x 15 | TUERCAS FLANGE | CUBRE CAJA ESCUADRA |

BULONERIA TP-CA230:

| CANT. | DESCRIPCION | MEDIDA | CON | UBICACIÓN |
|-------|--------------------|-------------|----------------------------------|----------------------------|
| 2 | TUERCAS FLANGE | 5/8 | | TORNILLO ESTIRA RESORTE |
| 12 | TORNILLOS | 3/8 x 1-1/2 | TUERCAS AUTOFRENANTES | EMBRAGUE |
| 20 | TORNILLOS C/CUADR | 3/8 x 1-1/2 | TUERCAS FLANGE Y COMUNES | CAJAS EJES DE MANDO |
| 9 | TORNILLOS | 3/8 x 1-1/4 | TUERCAS FLANGE | SUPLEMENTO CAJA COBERTOR |
| 6 | TORNILLOS | 3/8 x 3/4 | TUERCAS COMUNES Y GROWER | COBERTOR DE CRUCETAS |
| 8 | TOR TIPO TANQUE | ¼ x 2-3/4 | 8 TUERCAS FLANGE + 8 COMUNES | PUAS PLASTICAS |
| 2 | ALEMITES RECTOS | 1/8 GASS | | PUNTONES ORIGINAL |
| 2 | CHAVETAS R | 3 x 60 | | PERNO BALANCIN |
| 4 | TORNILLOS | | TUERCAS FLANGE | COBERTOR PLASTICO CRUCETAS |
| 5 | RULEMANES | 59207 | Y EL 207-2F SKF | |
| 1 | RULEMAN | 6307 2RS | | CAJA TP-CA3036 |
| 12 | MEDIAS CAJAS | 10-23870 | | |
| 2 | RESORTE ESTABILIZ. | 1313103 C1 | TORNILLO SUPERIOR | |
| 4 | ARANDELA GROWER | Ø 16 | | AJUSTE BASE CAJA |
| 2 | RETEN | DBH9409 | 40 x 90 x 8 | MULTIPLICADOR |
| 1 | RETEN | SAV10206 | 35 x 80 x 10 | CAJA TP-CA3036 |
| 1 | RETEN | SAV5277 | 55 x 90 x 13 | MULTIPLICADOR |
| 2 | GANCHOS DE CAPOT | | (0733-442514) | CAPOT |
| 4 | PUAS PLASTICAS | | (TP-394417 A1) | LATERAL PUNTON |
| 8 | CRUCETAS | | (K518) (CRUZ C/DADOS) | BARRAS DE MANDO |
| 2 | LATAS DE GRASA | | (TP-CA150) (MULTIPLEX EP2 x 1KG) | |
| 2 | FUELLES DE GOMA | | (800100101) | TP-CA 3047 |
| 2 | BURLETE CAJA | | (85-02024) | |

MANTENIMIENTO

TP-CA230

Recomendaciones de mantenimiento preventivo que se deben realizar después de la primera cosecha de trigo o soja.

Desmontar los rodamientos de las cabezas de cuchillas TP-CA3004 (der.) y TP-CA3052 (izq.), controlar su juego y verificar que ingrese grasa.

Reemplazar la brida plástica TP-CA137.

Aflojar los tornillos de ajuste de barras cardánicas laterales y retirar.

Girar el volante de la caja de cuchillas TP-CA2012-4 a mano para verificar su movimiento y rotación, debe ser liviano y sin golpes en la totalidad de su giro.

Desmontar las barras cardánicas.

Engrasar caño hembra y volver a precintar el fuelle.

Engrasar estría macho de la caja escuadra y ajustar.

Engrasar las estrías con ajuste o flotante.

Cambiar el aceite de la caja escuadra TP-CE100.

El aceite que utiliza esta caja es SAE 80W90; retirar tapón inferior, volver a colocar y retirar tapón lateral (nivel) y agregar el aceite nuevo por su parte superior y observar tapón lateral para su nivel, armar y ajustar tapones.

Cambiar el aceite SAE 80-90 de la caja multiplicadora mando sin fin entregador y mando izquierdo nivel visor lateral original.



Controlar el desgaste de las secciones de corte y puntones (reemplazar si es necesario) y regular guardas dejando estos bien cerca de las secciones. Las barras de cortes deben desplazarse sin interferencias y livianas.

Engrasar crucetas, controlar su estado y reajustar los tornillos de sujeción.

Controlar el zafe original, en la caja multiplicadora ver si la estría interna Z6 tiene desgaste.

Controlar los bolilleros de ejes de mando, retirar barras toma de fuerzas y girar a mano para controlar su giro y movimiento.



Revisar ensamble central (Puntones y secciones)

Controlar ajuste caja de cuchillas (Izq. y der.) si es necesario reemplazar arandelas planas inferiores cabeza de tornillo (cantidad 4 por lado)

Poner en marcha después de este mantenimiento y observar todo lo realizado (No debe haber pérdidas de aceite)

Seguir con el engrase periódico y no sobrepasar de grasa las cajas de cuchillas, siempre engrasar muñón inferior al finalizar jornada de trabajo de 2 o 3 bombazos y utilizar grasa recomendada por el fabricante Multiplex EP2



TP-CA2012-4

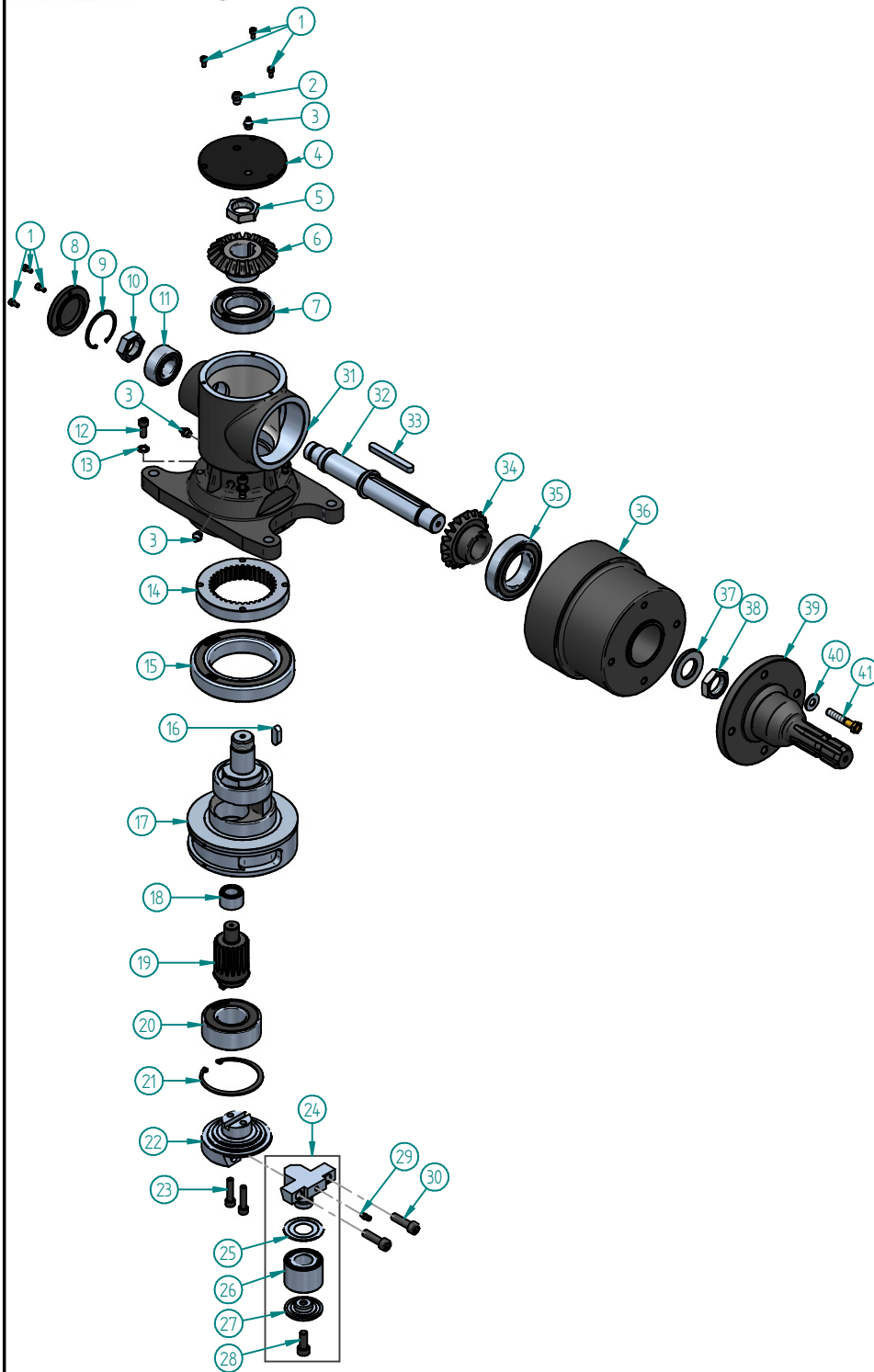

| Nº | Código | Descripción | Cant |
|----|------------|------------------------------------|------|
| 1 | TP-CA116 | Tornillo allen M5 x 10 | 6 |
| 2 | TP-CA121 | Respiradero de 1/8" GAS | 1 |
| 3 | TP-CA120 | Alemite de 1/8" GAS | 3 |
| 4 | TP-CA108 | Tapa Superior | 1 |
| 5 | TP-CA105 | Tuerca ajuste piñon | 1 |
| 6 | TP-CA114 | Piñon Z20 | 1 |
| 7 | TP-CA124 | Rodamiento 6209-2RS | 1 |
| 8 | TP-CA109 | Tapa lateral | 1 |
| 9 | TP-CA115 | Seguer 52 I | 1 |
| 10 | TP-CA106 | Tuerca ajuste rodamiento | 1 |
| 11 | TP-CA126 | Rodamiento 3205-2RS | 1 |
| 12 | TP-CA117 | Tornillo allen M8 x 25 | 4 |
| 13 | - | Arandela grower M8 | 4 |
| 14 | TP-CA103 | Corona Z36 | 1 |
| 15 | TP-CA122 | Rodamiento 6018-2RS | 1 |
| 16 | TP-CA134 | Chaveta 10 x 8 x 28 | 1 |
| 17 | TP-CA100 | Excentrico | 1 |
| 18 | TP-CA127 | Rodamiento | 1 |
| 19 | TP-CA110 | Piñon Z18 | 1 |
| 20 | TP-CA123 | Rodamiento 3208 | 1 |
| 21 | TP-CA132 | Seguer 80 I | 1 |
| 22 | TP-CA112 | Eje piñon muñon | 1 |
| 23 | TP-CA118 | Tornillo de M8 x 45 | 2 |
| 24 | TP-CA001 | Kit muñon TP-CA111 | 1 |
| 25 | TP-CA129-T | Tapa cubre rodamiento | |
| 26 | TP-CA129 | Rodamiento | |
| 27 | TP-CA136 | Tapa rodamiento externo | |
| 28 | TP-CA131 | Tornillo allen de M10 x 25 | |
| 29 | TP-CA138 | Alemite M6 x 1h | 1 |
| 30 | TP-CA119 | Tornillo allen M10 x 35 | 2 |
| 31 | TP-CA164 | Carcasa | 1 |
| 32 | TP-SA1117 | Eje superior mando | 1 |
| 33 | TP-SA1127 | Chaveta antar a 10 x 8 x 80 DIN | 1 |
| 34 | TP-CA113 | Engranaje cónico Z18 | 1 |
| 35 | TP-CA125 | Rodamiento 6210-2RS | 1 |
| 36 | TP-CA162 | Volante | 1 |
| 37 | TP-CA143 | Arandela | 1 |
| 38 | - | Tuerca 1-1/8" x 12 h | 1 |
| 39 | TP-MCO123 | Punta de eje para caja de cuchilla | 1 |
| 40 | - | Arandela plana de 3/8" | 4 |
| 41 | - | Tornillo M10 x 1,5 x 40 | 4 |

TECNOLOGIA PEREZ S.A.

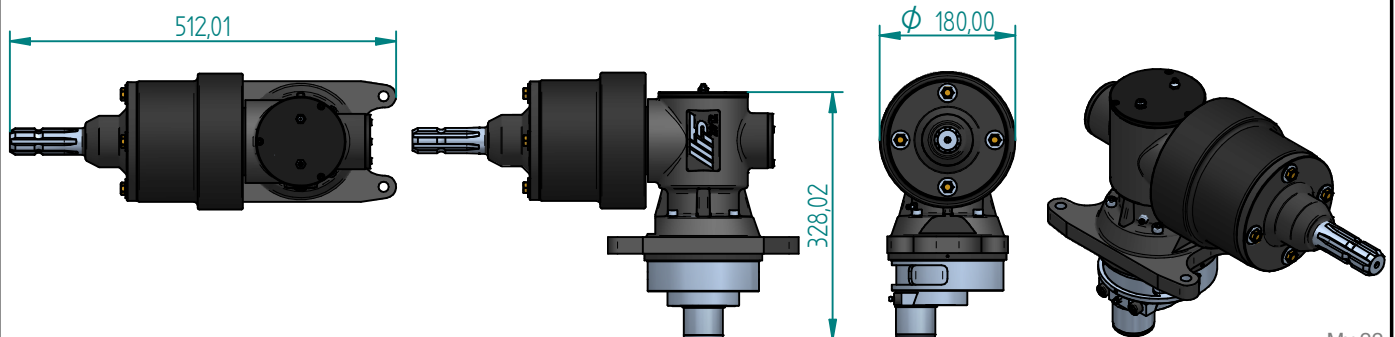



CAJA ESCUADRA TP-CE 100

| N° | Código | Descripción | Cant. |
|----|------------|--|-------|
| 1 | | SEGUER 35A | 2 |
| 2 | - | TORNILLO DE 10 x 1,5 x Largo 25 | 4 |
| 3 | - | RETÉN Ø80 x Ø50 x 10 | 2 |
| 4 | - | CHAVETA 10 x 8 x 36 | 1 |
| 5 | - | RODAMIENTO ZKL 30306 (Ø72 x Ø30) | 1 |
| 6 | - | RODAMIENTO ZKL 30207 | 3 |
| 7 | - | TORNILLO ALLEN 5 x 0,80 -HEXAGONO DE 4,00 mm | 3 |
| 8 | MB6 | SEGURO | 1 |
| 9 | TP-CA 104 | TUERCA AJUSTE PIÑÓN | 1 |
| 10 | TP-CE 010 | EJE SALIDA CAJA ESCUADRA MAIZCO | 1 |
| 11 | TP-CE 011 | EJE PIÑÓN DE MANDO CAJA MAIZCO | 1 |
| 12 | TP-CE 012 | ENGRANAJE CONICO Z-20 | 1 |
| 13 | TP-CE 014 | SEPARADOR RODAMIENTO | 1 |
| 14 | TP-CE 015 | ANILLO DE SEGURIDAD | 2 |
| 15 | TP-CE 017 | RESPIRADERO 3/8" x 19h BSPT | 1 |
| 16 | TP-CE 020 | CAJA RODAMIENTO | 1 |
| 17 | TP-CE 025 | TAPA LATERAL CAJA MAIZCO | 1 |
| 18 | TP-CE 030 | CARCASA | 1 |
| 19 | TP-SA 1019 | TAPON ROSCADO 3/8" x 19h BSPT | 2 |

